

The Performance Comparison of Digital Correlators like XF and FX for VLBI and Delta-DOR

Arathi.S.Nair¹, Salim Paul²

¹(*Electronics and Communication Engineering Department, Sree Chithra Thirunna College of Engineering, Kerala, India*)

²(*Electronics and Communication Engineering Department, Sree Chithra Thirunna College of Engineering, Kerala, India*)

Abstract: *The navigation of a spacecraft is done by means of communication of radio waves with earth ground stations. Delta Differential One- Way Ranging (Δ DOR), is a powerful interplanetary navigation technique, providing a direct measurement of the angular position of a spacecraft. Its principle is to measure the difference in the arrival time of a spacecraft signal at two ground stations, and calibrating it with an ICRF (International Celestial Reference Frame) quasar signal. Delta-DOR is an application of Very Long Base Line Interferometry (VLBI). The correlation processing is the core section of the receiving system and it gathers signals from independent antennas which are then processed to find essential data that are used for guidance and navigation of spacecraft. The aim of this work is to study the performance of different types of digital correlators like XF and FX type that are used in Radio Interferometry.*

Keywords: *Correlation Processing, Delta-DOR, Quasars, Radio Interferometry, VLBI*

I. Introduction

Spacecraft navigation to distant locations in the solar system requires a team of scientists and engineers using sophisticated radios, large antennas, computers, and precise timing equipment. A spacecraft navigation uses precisely timed radio signals sent back and forth to Earth. Navigators on Earth track its location and speed and transmit course adjustments. It involves measuring its radial distance, velocity and the angle. From these data, a mathematical model may be constructed and maintained, describing the history of a spacecraft's location in three-dimensional space over time. Any necessary corrections to a spacecraft's trajectory or orbit may be identified based on the model. Spacecraft navigation draws upon tracking data, which includes measurements of the Doppler shift of the downlink carrier and the pointing angles of DSN antennas. The navigation of earliest mission was done by Doppler and range alone. Though extremely precise in line-of-sight coordinates, the navigation system based on these data could not determine the spacecraft declination component. To address this, the Deep Space Network (DSN) developed the capability for VLBI measurements beginning in the late 1970s.

For navigation using radio interferometry techniques such as Very Long Baseline Interferometry (VLBI), the receiving antennas were separated by a large distance that it was to operate them independently with no real-time communication link. This was done by recording the data on magnetic tape and later cross-correlation at a central processing station is done.

Delta Differential One- Way Ranging (Δ DOR), is an application of VLBI and is a powerful interplanetary navigation technique. It measures the difference in the time of arrival of a spacecraft signal at two ground stations, and calibrating it with an ICRF (International Celestial Reference Frame) quasar signal. Delta-DOR allows determination of angular position of spacecraft which is done by measuring the geometric time delay between received radio signals at two geographically separated base stations. In Delta-DOR, the delay measurements of a spacecraft radio signals are compared with delay measurements of quasar signals which is nearer to the spacecraft. Delta-DOR can be used to increase the accuracy of deciding the Spacecraft position in deep space when combined with other navigation techniques. The Delta-DOR correlator system collects signals from independent antennas which are then processed to find out the essential data that are used for guidance and navigation of spacecraft[3]. The correlation processing is the core section of the Delta DOR data processing system, and the correlators for interferometry is divided into XF, FX, and Hybrid type.

II. Digital Correlators For Interferometric Observations

The main components of the interferometric receiving system are the antennas which transform the incident electric fields into voltage waveforms, the filters that select the frequency components to be processed, and the correlator that forms the averaged product of the signals. The correlator produces the cross-correlation of the two voltages fed to it.

Let $V_1(t)$ and $V_2(t)$ are the input voltages, then correlator output will be:

$$r(\tau) = \lim_{T \rightarrow \infty} \frac{1}{2T} \int_{-T}^T V_1(t) V_2^*(t-\tau) dt \quad (1)$$

where τ is the time by which voltage V_2 is delayed with respect to voltage V_1 . Fourier transform of $r(\tau)$ is the cross power spectrum, that is needed in observation of spectral lines. This is obtained by inserting a series of instrumental delays in the signal to find the cross-correlation as a function of τ .

Digital correlators are designed to function at the sampling frequency of the signals or at a submultiple resulting from dividing the bit stream from the sampler into a number of parallel streams. In the latter case, the number of correlator units must be proportionally increased, and their outputs can be additively combined.

III. XF Correlator

Digital correlators are classified into XF type and FX type. In XF correlator, cross correlation is done first, then Fourier transform is taken. But in an FX correlator, Fourier transformation is followed by cross-correlation.

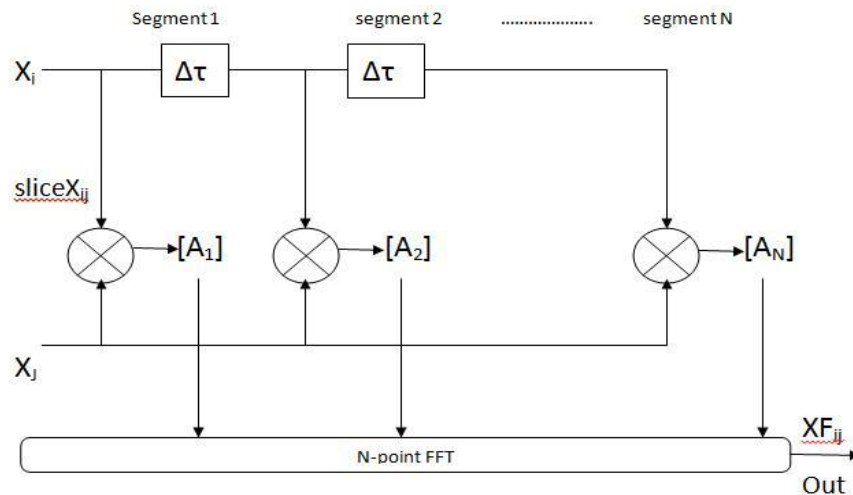

Fig 1: Block diagram of XF Correlator

Fig 1 shows the block diagram of the XF Correlator. It is seen that, input signal X_i and the originally delayed signal X_j are the inputs to the correlator slice X_{Fij} . We have to calculate the original time delay by successively inserting delay components to the signal X_i . That is the signal X_j is delayed by $\Delta\tau$, it is then multiplied and accumulated at every sample clock before propagating to the next segment. When the delays of X_i and X_j matches we get a peak in the correlation output and the delay value can be obtained by taking the Fourier transform result. The cross correlation operation is a function of lags (τ), which could be varied in quantization of $n\Delta\tau$ where $-N\Delta\tau/2 \leq n < N\Delta\tau/2$ where for a given observation bandwidth (Δf), $\Delta\tau$ is limited by $\Delta\tau_{min} = 1/(2 \times \Delta f)$ where Δf is the instantaneous bandwidth [1].

IV. FX Correlator

Fig 2 shows the block diagram of the FX Correlator. FX Correlator means Fourier transformation to the frequency domain is performed before cross multiplication of data from different antennas are done. In such a correlator, the input bit stream from each antenna is converted to a frequency spectrum by a real-time FFT, and then for each antenna pair, the complex amplitudes for each frequency are multiplied to produce the cross power spectrum. A major part of the computation occurs in the Fourier transformation, for which the total number of operations is proportional to the number of antennas.

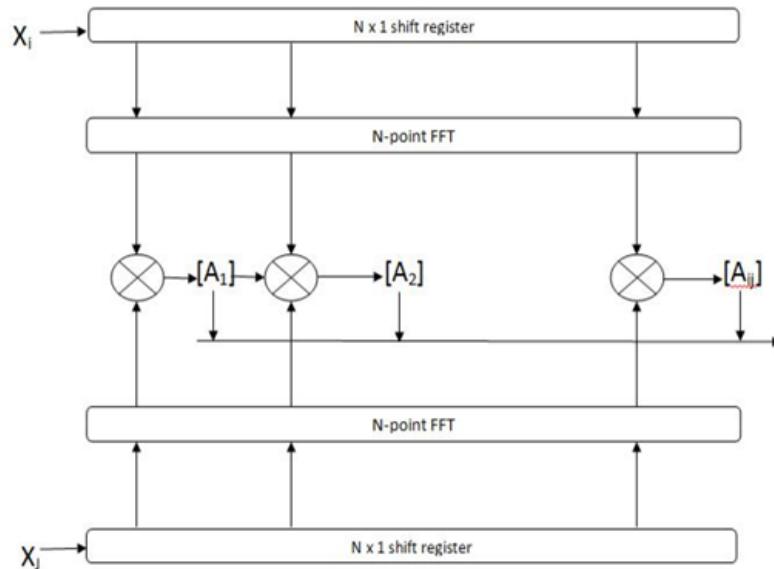

Fig 2: Block diagram of FX Correlator

The basic principle of the FX correlator, is based on the use of the FFT algorithm. Two different kinds of implementations of FX correlator are used [2]. In one, both in-phase and quadrature components of the signal are sampled to provide a sequence of N complex samples, it is then Fourier-transformed to get N values of complex amplitudes, distributed in positive and negative frequencies. In the next, N real samples are itself transformed to get N values of complex amplitude. However, the negative frequencies are redundant, and only $N=2$ spectral points need be stored. We discuss the second scheme in this paper. The input sample stream from an antenna is Fourier transformed in continuous sequences of length- N samples, where N is usually a power-of-two integer for efficiency in the FFT algorithm. The output of each transformation is a series of N complex signal amplitudes as a function of frequency. The frequency spacing of the data after transformation is $1/Nt_s$, where t_s is the time interval between samples of the signals. In the cross-multiplication process that follows the FFT stage, the complex amplitude from one antenna of each pair is multiplied by the complex conjugate of the amplitude of the other. This is expressed as correlation process. The main thing is that the data in any one input sequence are combined only with data from other antenna for the corresponding time sequence. This results some differences in the effective weighting of the data in the FX and XF designs.

V. Comparison of XF And FX Correlators

A. Spectral Response

In FX method, the FFT processor operates on segmented blocks of data in order to control the spectral resolution. The resulting correlation function formed from the block of data have N ways, or N possible multiplications for the zero lag component. There are less number of multiplications for increasing lags because of the data block boundaries. The correlator function at the maximum lags of $\pm (N - 1)t_s$ is get in only one way. Thus, the density of lag multiplications has a triangular shape as a function of lag over the range $\pm Nt_s$, as shown in Fig 3a. Thus the Fourier transform of this triangular function, is sinc^2 function, this is the spectral response. But in the XF method, the spectral resolution depends on the length of the correlation function. Since the correlation function is calculated on a segment of data this is much longer than the block length, thus the density of lag multiplications is uniform. Hence, its spectral response is sinc function itself. The spectral responses for the FX and XF correlators are shown in Fig 3b.

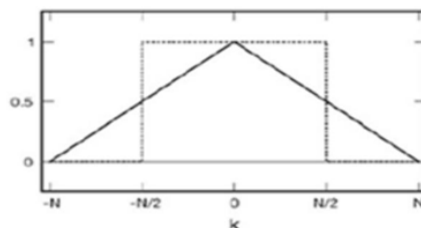

Fig3a : Density of Lag calculations of an FX Correlator (solid line) and XF Correlator (dotted line)

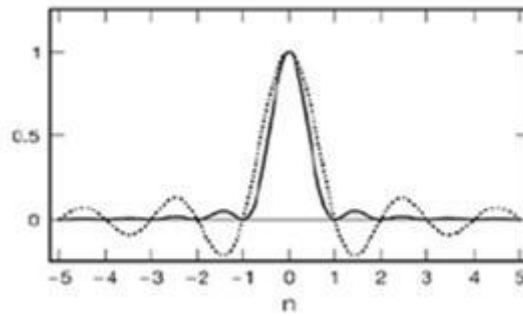

Fig3b : Spectral Response of FX Correlator (solid line) and XF correlator (dotted line).

B. Number of Computations

Assume that the data streams are at nyquist interval appropriate for instantaneous bandwidth Δf_i ; ie, $\Delta t_{min} = 1/(2 \times \Delta f_i)$ also assume that the the number of lags computed in the X engine (lag correlator), N , is equal to the data segment length into the F engine. This makes the spectral resolution of both systems approximately equal. Consider the analysis of 1 second of data; ie, $2\Delta f_i$ samples. For the XF system, a lag correlator is required for each baseline. Thus, $2N\Delta f_i$ multiplications are required for each baseline. Thus, the rate of multiplications (multiplications per second), r_{XF} , is;

$$r_{XF} = 2 \times f_i \times N \times nb \quad (2)$$

where nb is the number of baselines.

For the FX processor, one FFT engine is required for each antenna. We assume that the number of multiplications for the FFT implementation of the N -point FFT is $N \log_2 N$. The cross power spectrum calculation requires the pairwise cross multiplication of the outputs of DFT engines for all baselines. These multiplications are complex, requiring four real multiplications each. In addition, only the $N/2$ spectral points at positive frequencies need to be calculated and retained. The number of multiplications is therefore $[naN \log_2 N + 4Nnb/2]M$, where M is the number of segments processed, $2\Delta f_i/N$. Since $MN = 2\Delta f_i$, the overall multiplication rate is

$$r_{FX} = 2 \times f_i \times [na \log_2 N + 2nb] \quad (3)$$

In general larger the value of N or na ; the FX design is more favoured.

C. Signal to Noise Ratio

The FX covers twice the number of lags as the XF processor but has lower density as the lag number increases. For a continuous source, the signal-to-noise ratio of the FX and XF systems are same. This is because the zero lag multiplications in both systems are equal. The FX correlator has a larger range but fewer multiplications at lag $(k) \pm N/2$. The classic method to recover this loss of information is to overlap the segments in the block processing in the F engine. A 50% overlap recovers most of the lost signal-to-noise ratio but at a cost of doubling the processing time in the F engine.

VI. Results

Before implementing any correlator designs in Hardware Description Languages (HDL) like Vhdl & Verilog, simulations are performed in MATLAB. To study that how a correlator module behaves in a radio application, a simulated radio link is used to transmit data to a receiver. The receiver section do the quantization process of the data from the radio link, and it is applied to the correlate unit. The easiest way to verify the functioning of the correlation algorithm, is by correlating sine waves having different phases.

Recently most correlators made have been XF correlators partly due to the cost of designing a frequency transform engine and other factors. With the arrival of cost effective Field Programmable Gate Arrays (FPGAs) this becomes a main factor. Since in FPGAs the design is implemented using VHDL or Verilog and also the errors can be rectified in hours instead of months as in the case with dedicated Application Specific ICs. This provides the designs can be easily transformed into other systems. The FX correlator have low correlator efficiency because the traditional approach involves taking the FFT of non-overlapping data blocks. This results in increase in the correlator noise for narrow band signals. In this paper the correlation functioning of XF Correlator is analysed in MATLAB for different iterations of indexes like transmitting frequency, number of segments, integration length etc.

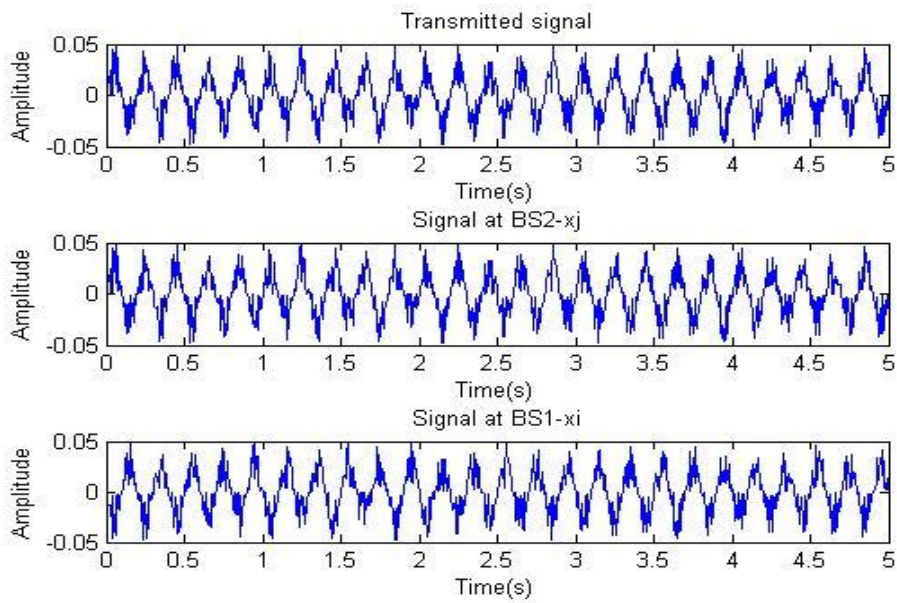

Fig4a: Simulated models of transmitted and received signals at two base stations.

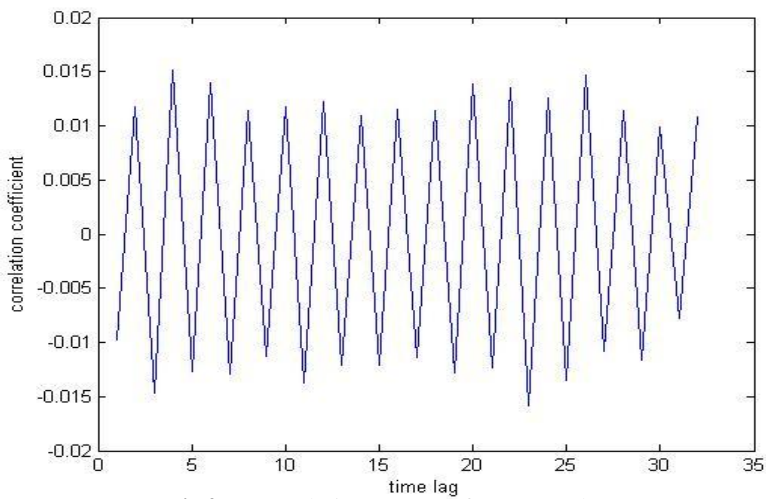

Fig4b: Correlation output of XF Correlator

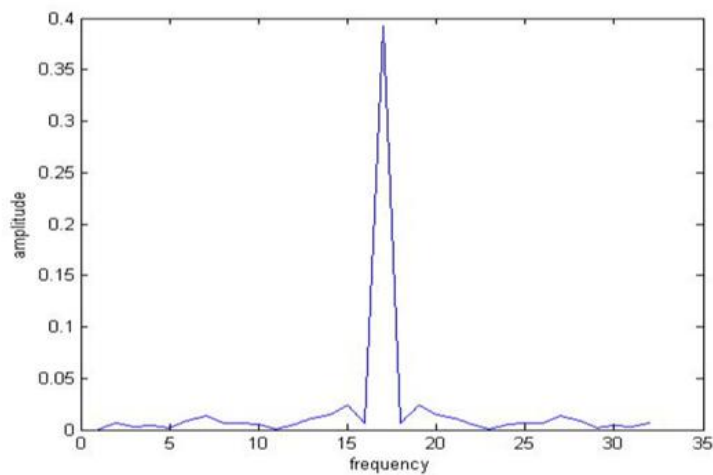

Fig4c: Spectral response of XF correlator

As shown in Fig4a, a transmitted signal of 5Hz is considered and the phase differenced sine waves are received at base station1 and base station2 are also shown. Also consider 1000 number of input samples of data which have a sampling interval of 0.005s. Let the number of segments be 32. Since the delay $\Delta\tau$ in XF Correlator is $1/(2*\text{transmitting frequency})$, here $\Delta\tau$ is 0.1s ; that is there are 20 number of samples in each $\Delta\tau$. Let us consider there is a total time delay of 0.3s, that is there must be 60 samples of delay. So we have to get a correlation peak at the fourth segment.

From Fig4b, it has been seen that the correlation peak value of 0.0152 is obtained at the fourth segment itself. While varying the integration length from 1 to 10 for a particular delay (here 3s), it is understood that always the correlation peak is obtained exactly at the required segment (here 4th segment). This shows the high stability in the results of XF Correlator rather than the FX correlator.

In Fig4c, the spectral response of 0.3s delay in the second base station Xj is shown. For XF correlator, the spectral resolution depends on the length of the correlation function, that is the integration length. Here the correlation function is obtained on a segment of data, so the density of lag multiplications is uniform. Thus, the spectral response for XF correlator is sinc function. It is observed that the side lobes of the spectrum varies with respect to the change in the integration length. Also the bandwidth of the spectrum changes according to the delay in Xj. By analysing the 3db bandwidth of the spectrum we can find out the total time delay also. But in the case of FX Correlator, since the density of lag multiplication plot is a triangular function, the spectral response will be sinc^2 function, so it will be difficult to do the bandwidth analysis. So from this study, it can be inferred that if there are less number of basestation antennas, the circuit complexity and thus the number of computations of XF correlator is less when compared to the FX Correlator. Also from the MATLAB results obtained, it is clear that if there are two base station antennas, the correlation results as well as the spectral response of the XF Correlator is more accurate than the FX Correlator.

VII. Conclusion

This paper discuss the interferometric methods of spacecraft navigation like VLBI and Delta-DOR. Delta-DOR being an application of VLBI allows the determination of angular position of spacecraft by measuring the geometric time delay between received radio signals at two geographically separated base stations. For measuring the effective time difference in the arrival of the signals, a digital correlator is used. The Delta-DOR correlator system gathers signals from independent antennas which are then processed to find essential data used for guidance and navigation of spacecraft. Then we discuss different types of digital correlators called XF and FX and studied both the frequency domain correlators in detail. After that, for analyzing the performance of XF and FX correlators, we have done a comparison of both these correlators in terms of Spectral response, Number of computations and Signal to Noise ratio performance. Atlast the performance of XF Correlator in terms of correlation results and spectral response is plotted and analysed for a time delay of 3sec in MATLAB. From that results it is seen that if there are two base station antennas, the correlation results as well as the spectral response of the XF Correlator is more accurate than the FX Correlator. Thus it has been proved that the XF Correlator will give a better performance than FX correlator ,if there are less number of antenna elements.

References

- [1] Raj Thilak Rajan, Mark Bentum, Andre Gunst, Albert.J.Boonstra *Distributed correlators for interferometry in space*, *IEEE*,2013
- [2] A.Richard Thompson, James.M.Moran, George.W.Swenson *Interferometry and synthesis in radio astronomy* (Third edition, Springer Open)
- [3] Chethan.R, Yogesh Prasad, Ravish Aradhya , Correlator based group delay measurement for Delta-DOR signals, proceedings of 2015 Global conference on communication technologies .IEEE , 2015.
- [4] Chikada, Yoshihiro “Correlators for interferometry-Today and Tomorrow” ASP Conference Series, Vol. 19, 1991.
- [5] Maoli Ma,Weimin Zheng,Yidan Huang,Guangli Wang, “The XF-type Correlator for Delta-DOR in deep space navigation” IVS 2014,general meeting proceedings.
- [6] “Delta-Differential One Way Ranging(Delta-DOR) operations”.,CCSDS.,White Book,June 2007
- [7] Bos.A., “A high-speed 2-bit correlator chip for radioastronomy” , IEEE Transactions. Instrum. Meas., 40(3), 591–595. IEEE 1991.
- [8] Bos, A., W. H. Aldrich, and A. R. Whitney , “The Haystack correlator chip” , EVN Doc., 237.,1996.
- [9] Whitney, A. R. ,” How do VLBI correlators work?”, paper presented at 2000 General Meeting, Int. VLBI Serv. For Geodesy and Astrometry, Ko`tzting, Germany,2000
- [10] Whitney, A. R., et al. , “Mark 4 VLBI correlator: Architecture and algorithms”, Radio Sci., 39, RS1007, doi:10.1029/2002RS002820., 2004.